

## Technical Documentation

**POS-123-U**  
**POS-123-P**  
**POS-123-U-SSI**

Universal positioning module, alternatively with power output stage or SSI interface



*Electronics*  
*Hydraulics* meets  
*meets* *Hydraulics*  
*Electronics*

## CONTENTS

1	General Information .....	4
1.1	Order number .....	4
1.2	Scope of supply .....	4
1.3	Accessories .....	4
1.4	Symbols used .....	5
1.5	Using this documentation .....	5
1.6	Legal notice .....	5
1.7	Safety instructions .....	6
2	Characteristics .....	7
2.1	Device description .....	8
3	Use and application .....	9
3.1	Installation instructions .....	9
3.2	Typical system structure .....	10
3.3	Method of operation .....	10
3.4	Commissioning .....	12
4	Technical description .....	13
4.1	Input and output signals .....	13
4.2	LED definitions .....	14
4.3	Circuit diagram .....	14
4.4	Typical wiring .....	15
4.5	Connection examples .....	15
4.6	Technical data .....	16
5	Parameters .....	17
5.1	Parameter overview .....	17
5.2	Configuration .....	19
5.2.1	LG (Changing the language) .....	19
5.2.2	MODE (Switching between parameter groups) .....	19
5.2.3	SENS (monitoring of the modul functions) .....	19
5.2.4	EOUT (Output signal: READY = OFF) .....	20
5.2.5	HAND (Manual speed) .....	20
5.2.6	INPOS (In position range) .....	21
5.3	Signal adaptation .....	21
5.3.1	SYS_RANGE (Working stroke) .....	21
5.3.2	SIGNAL (Type of input) .....	21
5.3.3	N_RANGE:X (Nominal range of the sensor) .....	22
5.3.4	OFFSET:X (Sensor offset) .....	22
5.3.5	Using of the commands SYS_RANGE, N_RANGE:X and OFFSET:X .....	23
5.4	Speed commands .....	24
5.4.1	VELO (Internal speed demand value) .....	24
5.4.2	VRAMP (Ramp time for external speed demand) .....	24
5.5	Profile generator .....	25
5.5.1	VMODE (Methode of positioning) .....	25
5.5.1	ACCEL (Acceleration in NC mode) .....	25
5.5.2	VMAX (Maximum speed in NC mode) .....	25
5.6	Control parameter .....	26
5.6.1	A (Acceleration (ramp) time) .....	26
5.6.2	D (Deceleration / braking distance) .....	26
5.6.3	V <sub>0</sub> (Loop gain setting) .....	27
5.6.4	V0:RES (Scaling of the loop gain) .....	27
5.6.5	PT1 (Timing of the controller) .....	28
5.6.6	CTRL (Deceleration characteristics) .....	28
5.7	Output signal adaptation .....	29

5.7.1	MIN (Deadband compensation)	29
5.7.2	MAX (Output scaling)	29
5.7.3	TRIGGER (Response threshold for the MIN parameter)	29
5.7.4	OFFSET (Zero correction)	30
5.7.5	SIGNAL:U (Type and polarity of the output signal)	30
5.8	Special commands	31
5.8.1	Drift compensation / high accurate positioning	31
5.8.2	AINMODE	33
5.9	Process data	34
6	Appendix	35
6.1	Failure monitoring	35
6.2	Troubleshooting	35
6.3	Description of the command structure	37
7	ADDITIONAL INFORMATION: Power output stage	38
7.1	General function	38
7.2	Device description	39
7.3	Inputs and outputs	40
7.4	Circuit diagram	41
7.5	Typical wiring	42
7.6	Technical data	42
7.7	Parameter overview of the power stage	43
7.8	Parameter description of the power stage	43
7.8.1	SIGNAL:M (Type of the monitor output signal)	43
7.8.2	SIGNAL:U (Polarity of the output signal)	43
7.8.3	CURRENT (Rated output current)	44
7.8.4	DFREQ (Dither frequency)	44
7.8.5	DAMPL (Dither amplitude)	44
7.8.6	PWM (PWM Frequenz)	44
7.8.7	ACC (Current loop ato adjustment)	45
7.8.8	PPWM (Solenoid current controller P element)	45
7.8.9	IPWM (Solenoid current controller I element)	45
7.9	Special Functions	46
7.9.1	IMS (Theoretical maximum current drain)	46
7.9.2	SOLERR (Function of the wire break monitoring)	46
8	ADDITIONAL INFORMATION: SSI interface	47
8.1	General function	47
8.2	Device description	48
8.3	Inputs and outputs	49
8.4	Circuit diagram	49
8.5	Typical wiring	51
8.6	Technical data	51
8.7	Special versions	52
8.8	Parameter overview of the SSI interface	52
8.9	Parameter description of the SSI interface	52
8.9.1	SELECT:X (Define sensor type)	52
8.9.2	SSI:RANGE (Sensor nominal length)	53
8.9.3	SSI:OFFSET (Sensor offset)	53
8.9.4	SSI:POL (Signal direction)	53
8.9.5	SSI:RES (Signal resolution)	53
8.9.6	SSI:BITS (Number of data bits)	54
8.9.7	SSI:CODE (Signal coding)	54
8.9.8	SSI:ERRBIT (Position of the "out of range" bit)	54
9	Notes	55

## 1 General Information

### 1.1 Order number

- POS-123-U** - with programmable output ( $\pm 10$  V differential output or 4... 20 mA) and analogue sensor interface
- POS-123-P** - with integrated power output stage up to 2,6 A (see *additional information*)
- POS-123-U-SSI** - with programmable output ( $\pm 10$  V differential output or 4... 20 mA), SSI sensor interface and 0... 10 V output as a diagnosis signal for the SSI sensor (see *additional information*)

#### Extended or alternative versions

- POS-323-P** - with commissioning assistant and integrated power output stage up to 2,6 A
- POS-123-P-PFN** - with Profinet interface and integrated power output stage up to 2,6 A
- POS-123-U-SSI-S1** - Special version of the positioning controller with SSI interface: The monitoring output on PIN 17 is realized as 4... 20 mA signal.
- UHC-126-U-PDP** - with extended position and pressure control, SSI or analogue sensor interface and Profibus interface
- UHC-126-U-PFN** - with extended position and pressure control, SSI or analogue sensor interface and Profinet interface
- UHC-126-U-ETC** - with extended position and pressure control, SSI or analogue sensor interface and Ethercat interface

### 1.2 Scope of supply

The scope of supply includes the module plus the terminal blocks which are part of the housing. The Profibus plug, interface cables and further parts which may be required should be ordered separately. This documentation can be downloaded as a PDF file from [www.w-e-st.de](http://www.w-e-st.de).

### 1.3 Accessories

- WPC-300** - Start-Up-Tool (downloadable from our homepage – products/software)

## 1.4 Symbols used



General information



Safety-related information

## 1.5 Using this documentation

Structure of the documentation:

The standard product is described up to chapter 6. The extensions like POWER STAGE or SSI-INTERFACE are described in the chapters ADDITIONAL INFORMATION.

## 1.6 Legal notice

**W.E.St.** Elektronik GmbH

Gewerbering 31  
D-41372 Niederkrüchten

Tel.: +49 (0)2163 577355-0  
Fax.: +49 (0)2163 577355-11

Home page: [www.w-e-st.de](http://www.w-e-st.de)  
EMAIL: [contact@w-e-st.de](mailto:contact@w-e-st.de)

Datum: 05.03.2026

The data and characteristics described herein serve only to describe the product. The user is required to evaluate this data and to check suitability for the particular application. General suitability cannot be inferred from this document. We reserve the right to make technical modifications due to further development of the product described in this manual. The technical information and dimensions are non-binding. No claims may be made based on them.

This document is protected by copyright.

## 1.7 Safety instructions

Please read this document and the safety instructions carefully. This document will help to define the product area of application and to put it into operation. Additional documents (WPC-300 for the start-up software) and knowledge of the application should be taken into account or be available.

General regulations and laws (depending on the country: e. g. accident prevention and environmental protection) must be complied with.



These modules are designed for hydraulic applications in open or closed-loop control circuits. Uncontrolled movements can be caused by device defects (in the hydraulic module or the components), application errors and electrical faults. Work on the drive or the electronics must only be carried out whilst the equipment is switched off and not under pressure.



This handbook describes the functions and the electrical connections for this electronic assembly. All technical documents which pertain to the system must be complied with when commissioning.



This device may only be connected and put into operation by trained specialist staff. The instruction manual must be read with care. The installation instructions and the commissioning instructions must be followed. Guarantee and liability claims are invalid if the instructions are not complied with and/or in case of incorrect installation or inappropriate use.



### **CAUTION!**

All electronic modules are manufactured to a high quality. Malfunctions due to the failure of components cannot, however, be excluded. Despite extensive testing the same also applies for the software. If these devices are deployed in safety-relevant applications, suitable external measures must be taken to guarantee the necessary safety. The same applies for faults which affect safety. No liability can be assumed for possible damage.



### **Further instructions**

- The module may only be operated in compliance with the national EMC regulations. It is the user's responsibility to adhere to these regulations.
- The device is only intended for use in the commercial sector.
- When not in use the module must be protected from the effects of the weather, contamination and mechanical damage.
- The module may not be used in an explosive environment.
- To ensure adequate cooling the ventilation slots must not be covered.
- The device must be disposed of in accordance with national statutory provisions.

## 2 Characteristics

This electronic module has been developed for controlling hydraulic positioning drives. Proportional valves with integrated or external electronics can be controlled with the differential output.

The internal profile generation is optimized for stroke-dependent deceleration or the NC control mode. The controller and the controller settings are adapted to typical requirements and thus permit rapid and uncritical optimization of the control behavior. The optimized control function offers a high degree of precision together with high stability for hydraulic drives. The movement cycle is controlled via the external position and speed inputs.

The high resolution of the analogue signals ensures good positioning behavior.

Alternatively, the P version is available with an integrated power output stage (see additional information: POWER OUTPUT STAGE). The advantage of the integrated power output stage is founded in the integrated control behavior without additional dead times. This allows higher dynamics and higher stability respectively.

The SSI extension is available for use with digital sensors (see additional information: SSI INTERFACE). Sensors with a resolution of one  $\mu\text{m}$  can be used for very high position accuracy.

Setting up this module is simple and easy to handle with our WPC-300 start-up software.

Typical applications: general positioning drives, fast transport drives, handling systems, speed-controlled axes and also tracer control.

## Features

- **Analogue position and speed inputs**
- **Analogue feedback sensors**
- **Simple and intuitive scaling of the sensor**
- **Optional: start-up assistant for fast and simple adjusting of the control parameter**
- **Motion command values in mm resp. mm/s**
- **Internal profile definition by acceleration, velocity and deceleration**
- **Principle of stroke-dependent deceleration for fast and robust positioning**
- **NC profile generator for constant speed**
- **Expanded closed loop control technology**
- **Highest positioning accuracy by using the drift compensation**
- **Usable with overlapped proportional valves and with zero lapped control valves**
- **Fault diagnosis and extended function checking**
- **Simplified parameterization with WPC-300 software**
- **Optionally:**
  - **Integrated power output stage (P version)**
  - **SSI Sensor interface**

## 2.1 Device description

Standard module – for the P-Version look at point 7.2

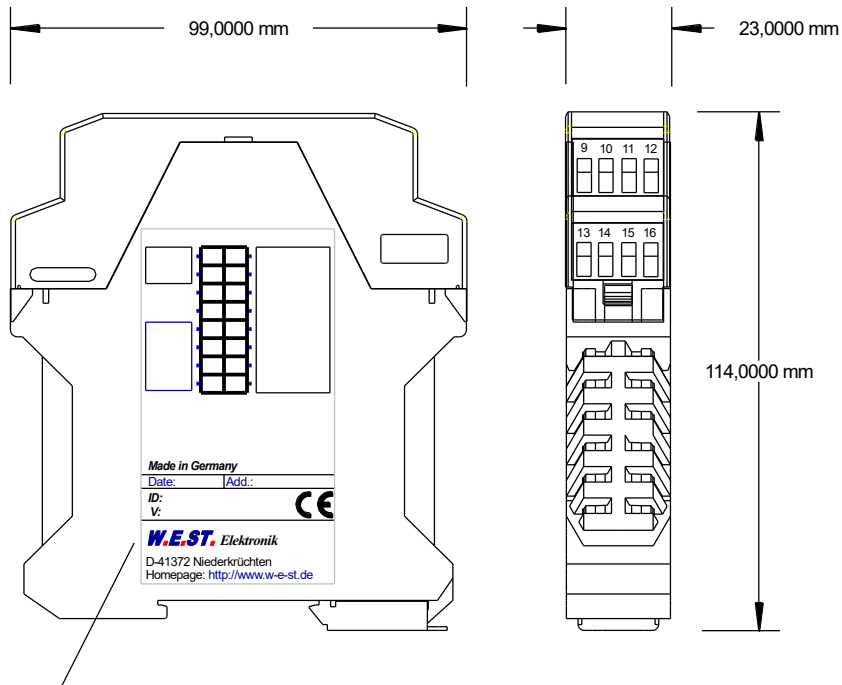

Type plate and terminal pin assignment

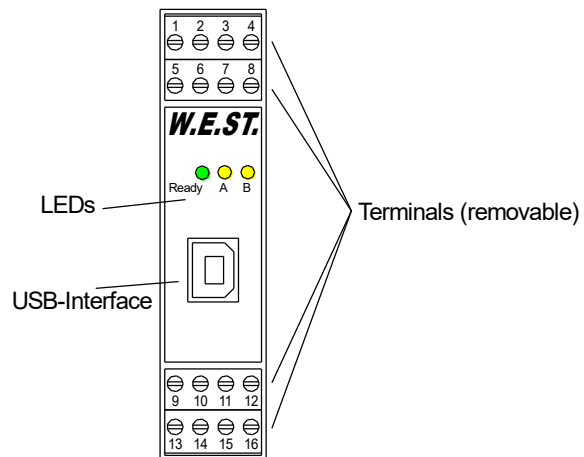

## 3 Use and application

### 3.1 Installation instructions

- This module is designed for installation in a shielded EMC housing (control cabinet). All cables which lead outside must be screened; complete screening is required. It is also necessary to avoid strong electro-magnetic interference sources being installed nearby when using our open and closed loop control modules.
- **Typical installation location:** 24 V control signal area (close to PLC)  
The devices must be arranged in the control cabinet so that the power section and the signal section are separate from each other.  
Experience shows that the installation place close to the PLC (24 V area) is most suitable. All digital and analogue inputs and outputs are fitted with filters and surge absorbers in the device.
- The module should be installed and wired in accordance with the documentation bearing in mind EMC principles. If other consumers are operated with the same power supply, a star-shaped ground wiring scheme is recommended. The following points must be observed when wiring:
  - The signal cables must be laid separately from power cables.
  - Analogue signal cables **must be screened**.
  - All other cables must be screened if there are powerful interference sources (frequency converters, power contactors) and cable lengths > 3 m. Inexpensive SMD ferrites can be used with high-frequency radiation.
  - The screening should be connected to PE (PE terminal) as close to the module as possible. The local requirements for screening must be taken into account in all cases. The screening should be connected to at both ends. Equipotential bonding must be provided where there are differences between the connected electrical components.
  - If having longer lengths of cable (> 10 m), the diameters and screening measures should be checked by specialists (e. g. for possible interference, noise sources and voltage drop). Special care is required if using cables of over 40 m in length, and if necessary the manufacturer should be consulted if necessary.
- A low-resistance connection between PE and the mounting rail should be provided. Transient interference is transmitted from the module directly to the mounting rail and from there to the local earth.
- Power should be supplied by a regulated power supply unit (typically a PELV system complying with IEC364-4-4, secure low voltage). The low internal resistance of regulated power supplies gives better interference voltage dissipation, which improves the signal quality of high-resolution sensors in particular. Switched inductances (relays and valve coils) which are connected to the same power supply must always be provided with appropriate overvoltage protection directly at the coil.

## 3.2 Typical system structure

This minimal system consists of the following components:

- (\*1) Proportional valve (or control valve): the valve type determines the precision. It is expedient to use control valves with integrated electronics.
- (\*2) Hydraulic cylinder
- (\*3) Integrated analogue or SSI position sensor (alternatively also with external position sensor)
- (\*4) POS-123-\* control module
- (\*5) Interface to PLC with analogue and digital signals

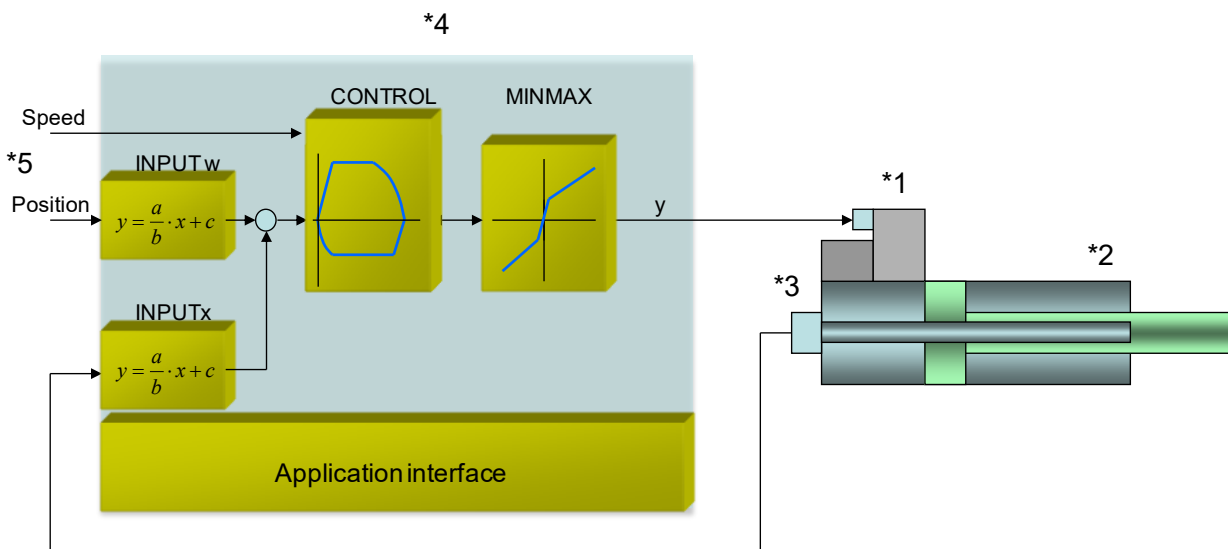

## 3.3 Method of operation

This control module supports simple point-to-point positioning with hydraulic drives. The system works on the principle of stroke-dependent deceleration, i. e. the control gain (deceleration stroke) is set via parameters **D:A** and **D:B**. Alternatively the loop gain will be used in NC mode. In this mode the velocity is controlled and the profile ist defined by the velocity and the acceleration.

The deceleration characteristics can be set linearly (**LIN**) or approximately quadratically (**SQRT1**) via the **CTRL** parameter. For normal proportional valves **SQRT1** is the input setting.

For control valves with a linear flow curve it depends on the application. If **LIN** is selected for these valves, a significantly shorter deceleration distance can often be set (**D:A** and **D:B**).

### Positioning sequence:

The positioning procedure is controlled by the switching inputs. After the **ENABLE** signal is applied, the required position equal to the actual position is set in the module and the drive remains stationary under control at the current position. The general readiness for operation is now reported via the **READY** output. The **START** signal activates the analogue demand value input (PIN 13) which is accepted as the new required position. The drive moves directly to the new required position and reports the reached position via the **InPos** output. The **InPos** output remains active as long as the position is maintained and as long as the **START** signal remains applied.

In manual mode (*START* disabled) the drive can be moved by means of *HAND+* or *HAND-*. The drive moves under open-loop control at the programmed manual speeds.

When the *HAND* (+ or -) signal is switched off, the current actual position is accepted as the required position and the drive comes to a controlled stop.

The *HAND* mode can be used – in case of a sensor failure – to drive the axis manually.

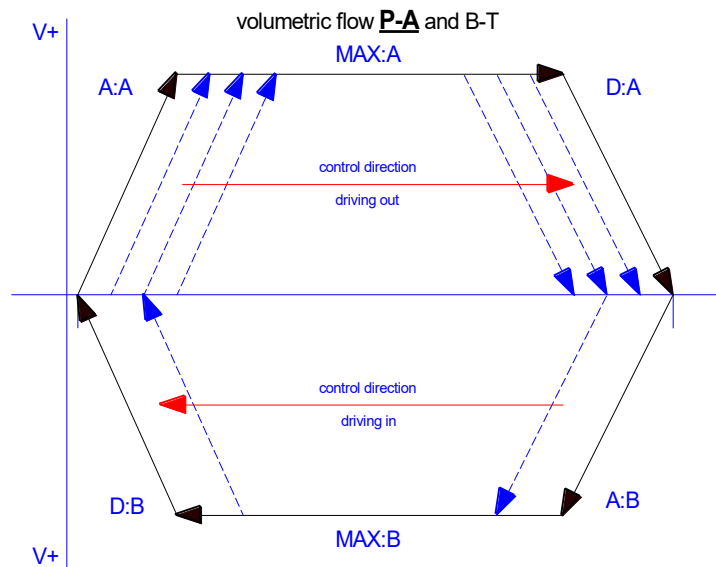

### Influences on positioning accuracy:

The positioning accuracy is determined by the hydraulic and mechanical conditions. The right choice of valve is therefore a decisive factor. In addition, two mutually contradictory requirements (short position time and high accuracy) must be taken into account when designing the system.

The electronic limitations lie mainly in the resolution of the analogue signals, although a resolution of < 0,01 % only needs to be considered for our modules with long positions. In addition, the linearity of the individual signal points (PLC, sensor and control module) must be taken into account.

It is generally recommended to calculate the static and dynamic behavior of the hydraulic axis. For supporting this, following technical basic data are required:

- minimum natural frequency of the cylinder,
- maximum theoretical speed for extending and retracting,
- valve characteristics (natural frequency, overlapped or zero lapped, hysteresis and the flow gain (flow and pressure drop),
- system pressure, maximum pump flow,
- and a description of the general system requirements.

## 3.4 Commissioning

Step	Task
Installation	Install the device in accordance with the circuit diagram. Ensure it is wired correctly and that the signals are well shielded. The device must be installed in a protective housing (control cabinet or similar).
Switching on for the first time	Ensure that no unwanted movement is possible in the drive (e. g. switch off the hydraulics). Connect an ammeter and check the current consumed by the device. If it is higher than specified, there is an error in the wiring. Switch the device off immediately and check the wiring.
Setting up communication	Once the power input is correct, the PC (notebook) should be connected to the serial interface. Please see the WPC-300 program documentation for how to set up communication. Further commissioning and diagnosis are supported by the operating software.
Pre-parameterization	Now set up the following parameters (with reference to the system design and circuit diagrams): The SYS_RANGE, SENSOR SETTING, POLARITY, ACCELERATION and DECELERATION. Pre-parameterization is necessary to minimize the risk of uncontrolled movements. Parameterize specific settings for the control element (MIN for deadzone compensation and MAX for maximum velocity). Reduce the speed limitation (VELO command) to a value which is uncritical for the application.
Control signal	Check the control signal with a voltmeter. The control signal (PIN 15 to PIN16) lies in the range of $\pm 10$ V. In the current state it should be 0 V. Alternatively, if current signals are used, approx. 0 mA should flow.
Switching on the hydraulics	The hydraulics can now be switched on. Since the module is not yet generating a signal, the drive should be at a standstill or drift slightly (leave its position at a slow speed).
Activating ENABLE	<b>CAUTION!</b> The drive can now leave its position and move to an end position at full speed. Take safety measures to prevent personal injury and damage. The drive stays in the current position (with ENABLE the actual position is accepted as the required position). If the drive moves to an end position, the polarity is probably wrong.
Speed demand	The speed can be limited by means of the VELO parameter or the external speed demand (VS = EXT).
Manual (HAND) operation	If START is disabled, the axis can be moved manually with HAND+ or HAND-. After disabling the HAND signal, the axis stops in a controlled manner at the current position. <b>CAUTION!</b> Please check the manual operation in conjunction with the EOUT command. If the EOUT is active do not use the manual operation.
Activating START	With the start signal the demand value of the analogue demand value input is accepted and the axis moves to the predefined target position. If START is disabled, the axis stops in the preset deceleration distance D:S.
Optimize controller	Now optimize the control parameters according to your application and your requirements.

## 4 Technical description

### 4.1 Input and output signals

Connection	Supply
PIN 3	Power supply (see technical data)
PIN 4	0 V (GND) connection.
Connection	Analogue signals
PIN 9 / 10	External speed demand (V), range 0... 10 V or 4... 20 mA (scalable)
PIN 13	Position demand value (W), range 0... 10 V or 4... 20 mA (scalable)
PIN 14	Analogue position actual value (X), range 0... 10 V or 4... 20 mA (scalable)
PIN 11 / PIN 12	0 V (GND) connection for analogue signals
PIN 15 / 16	Valve control signal. For current signal use output PIN 15 against 12, PIN16 is only for bipolar voltage signal. Type of signal and polarity can be selected by the parameter SIGNAL:U.
Connection	Digital inputs and outputs
PIN 8	<b>Enable input:</b> This digital input signal initializes the application and error messages are deleted. The controller and the READY signal are activated. The output signal to the control element is enabled. The actual position is accepted as the command position and the drive remains stationary under control at this position. If the input is disabled, the output (control signal) is switched off(disabled). Take care of the EOUT-command!
PIN 7	<b>START (RUN) input:</b> The position controller is active and the external analogue demand position is accepted as the demand value. If the input is disabled during the movement, the system is stopped within the set emergency stopping distance (D:S).
PIN 6	<b>HAND + input:</b> Manual operation (START = OFF): the drive moves at the programmed speed in the programmed direction. After deactivation, the actual current position is accepted as the demand position. The START (RUN) input has priority over the HAND+ input. If the sensor signal is missing (external ENABLE signal = ON), the drive can be operated in manual mode.
PIN 5	<b>HAND - input:</b> Manual operation (START = OFF); the drive moves with the programmed speed in the programmed direction. After deactivation, the actual current position is accepted as the required position. The START (RUN) input has priority over the HAND- input. If the sensor signal is missing (external ENABLE signal = ON), the drive can be operated in manual mode.
PIN 1	<b>READY output:</b> <b>ON:</b> The module is enabled; there are no discernable errors. <b>OFF:</b> Enable (PIN 8) is disabled or an error (sensor or internal error) has been detected.
PIN 2	<b>STATUS output:</b> <b>ON: INPOS message.</b> The axis is within the INPOS window. <b>OFF: INPOS message.</b> The axis is outside the INPOS window.

## 4.2 LED definitions

LEDs	Description of the LED function
GREEN	Identical to the READY output. <b>OFF:</b> No power supply or ENABLE is not activated <b>ON:</b> System is ready for peration <b>Flashing:</b> Error discovered Only active when SENS = ON
YELLOW A	Identical to the STATUS output. <b>OFF:</b> The axis is outside the INPOS window. <b>ON:</b> The axis is within the INPOS window.
GREEN + YELLOW A+B	1. <b>Chasing light (over all LEDs):</b> The bootloader is active. No normal functions are possible. 2. <b>All LEDs flash shortly every 6 s:</b> An internal data error was detected and corrected automatically! The module still works regularly. To acknowledge the error the module has to be cycle powered.
YELLOW A + YELLOW B	<b>Both yellow LEDs flash oppositely every 1 s:</b> The nonvolatile stored parameters are inconsistent! To acknowledge the error, the data have to be saved with the SAVE command or the corresponding button in the WPC. If the function of the module has changed via the FUNCTION parameter, all parameters are deleted purposely and set to default values. In this case the LEDs indicate no error, but a desired state. To acknowledge please save.

## 4.3 Circuit diagram

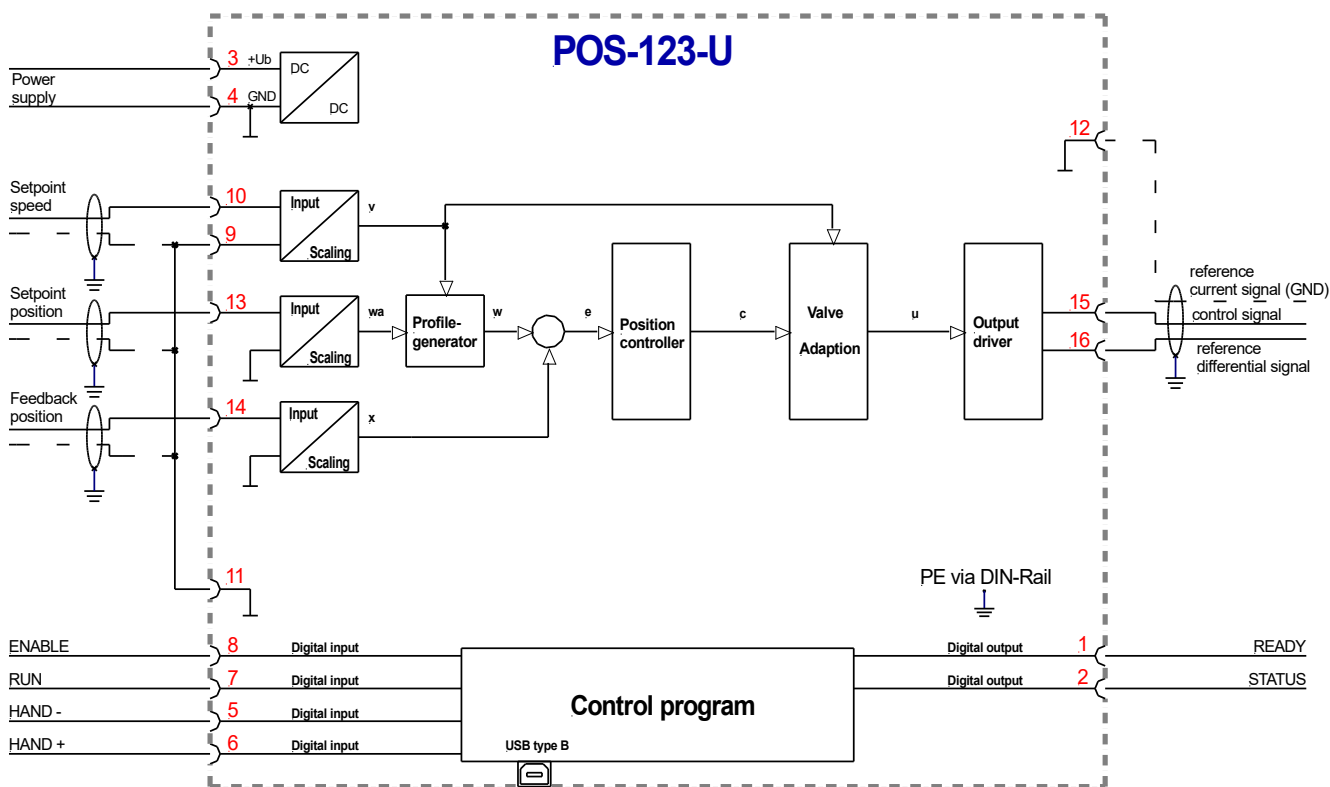

## 4.4 Typical wiring

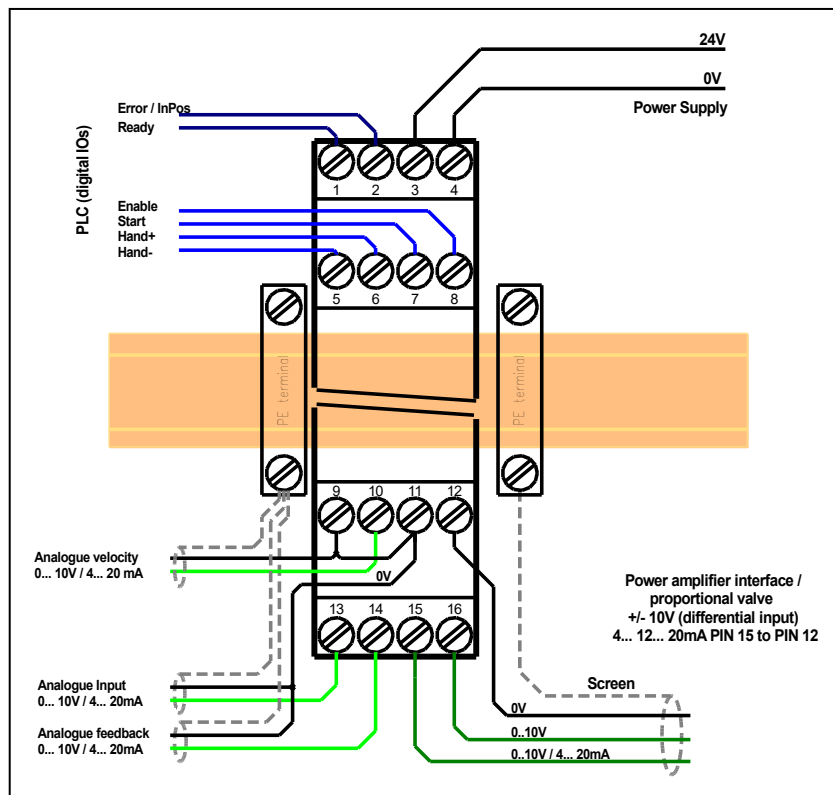

## 4.5 Connection examples

SPS / PLC 0... 10 V speed input signal

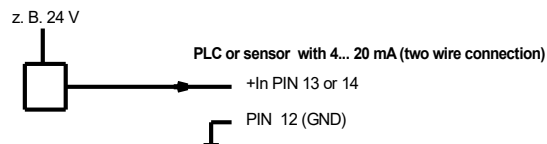
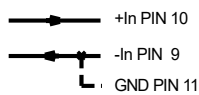

SPS / PLC 0... 10 V command and feedback signal

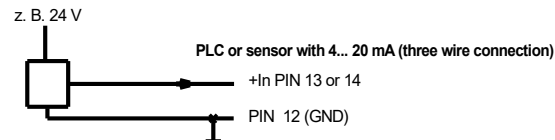
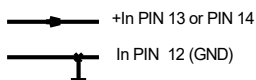

Valve (6 + PE plug) with OBE electronics, voltage signal +/- 10V

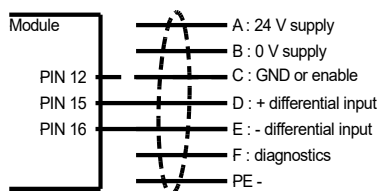

Valve (6 + PE plug) with OBE electronics, current signal 4-12-20 mA

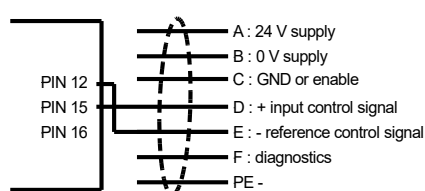

## 4.6 Technical data

Supply voltage (U <sub>b</sub> )	<b>[VDC]</b>	12... 30 (incl. ripple)
Power consumption	<b>[W]</b>	max. 2,5
External protection	<b>[A]</b>	1 medium time lag
Digital inputs		
OFF	<b>[V]</b>	< 2
ON	<b>[V]</b>	> 10
Input resistance	<b>[kOhm]</b>	25
Digital outputs		
OFF	<b>[V]</b>	< 2
ON	<b>[V]</b>	max. U <sub>b</sub>
Maximum current	<b>[mA]</b>	50
Analogue inputs		
Voltage	<b>[V]</b>	Unipolar 0... 10
Input resistance	<b>[kOhm]</b>	min. 25
Signal resolution	<b>[%]</b>	0.003 incl. Oversampling
Current	<b>[mA]</b>	4... 20
Burden	<b>[Ohm]</b>	240 Ohm
Signal resolution	<b>[%]</b>	0.006 incl. Oversampling
Analogue outputs		
Voltage	<b>[V]</b>	0... 10, +/- 10 differential
Maximum load	<b>[mA]</b>	10
Current	<b>[mA]</b>	4... 20
Maximum load	<b>[Ohm]</b>	390
Signal resolution	<b>[%]</b>	0.007
Controller cycle times		
Signal processing	<b>[ms]</b>	1
Serial interface	-	USB - virtual COM Port
Transmission rate	<b>[kBaud]</b>	9.6... 115.2
Housing		
Material	-	PA 6.6 polyamide
Flammability class	-	V0 (UL94)
Weight	<b>[kg]</b>	0.17
Protection class	<b>[IP]</b>	20
Temperature range	<b>[°C]</b>	-20... 60
Storage temperature	<b>[°C]</b>	-20... 70
Humidity	<b>[%]</b>	< 95 (non-condensing)
Connections	-	
Communication		USB type B
Plug connectors		4 x 4-pole terminal blocks
PE		via the DIN mounting rail
EMC	-	EN 61000-6-2: 8/2005 EN 61000-6-4: 6/2007 + A1:2011

## 5 Parameters

### 5.1 Parameter overview

Group	Command	Default	Unit	Description
<b>Basic parameter</b>				
	LG	EN	-	Changing language help texts
	MODE	STD	-	Parameter view
	SENS	ON	-	Malfunction monitor
	EOUT	0	0.01 %	Output signal if no ready
	HAND : A	3330	0.01 %	Output signal in manual mode
	HAND : B	-3330	0.01 %	
	INPOS	200	µm	Range of the in position monitoring
<b>Signal adaptation</b>				
	SYS_RANGE	100	Mm	Axis working stroke
<b>Sensor scaling</b>				
	SIGNAL : X	U0-10		Type of input
	N_RANGE : X	100	Mm	Nominal range
	OFFSET : X	0	µm	Offset value
<b>Input scaling</b>				
	SIGNAL : W	U0-10	-	Type of input
<b>Speed input</b>				
	SIGNAL : V	OFF	-	Type of input
	VELO	10000	0.01 %	Internal speed value
	VRAMP	200	ms	External speed ramp time
<b>Profile generator</b>				
	VMODE	SDD	-	Method of positioning
	ACCEL	250	mm/s <sup>2</sup>	Acceleration in NC mode
	VMAX	50	mm/s	Maximum speed in NC mode
<b>Closed loop control parameter</b>				
	A : A	100	ms	Acceleration (ramp times) in SDD mode
	A : B	100	ms	
	D : A	25	mm	Deceleration stroke in SDD mode
	D : B	25	mm	
	D : S	10	mm	
	V0 : A	10	1/s	Closed loop gain in NC mode
	V0 : B	10	1/s	
	V0 : RES	1	-	
	PT1	1	ms	PT1 time constant
	CTRL	SQRT1	-	Control characteristics

Output signal adaptation				
MIN : A	0	0.01 %	Deadband compensation or flow characteristic linearization	
MIN : B	0	0.01 %		
MAX : A	10000	0.01 %	Output scaling	
MAX : B	10000	0.01 %		
TRIGGER	200	0.01 %	Deadband compensation trigger point	
OFFSET	0	0.01 %	Output offset value	
SIGNAL : U	U+-10	-	Type of output signal and polarity	
Special commands				
<i>Drift compensator</i>				
DC : AV	0	0.01 %	Control parameter of the drift compensator DC:AV = point of activation DC:DV = point of deactivation DC:I = Time of the integrator DC:CR = Limit of the maximum output	
DC : DV	0	0.01 %		
DC : I	2000	ms		
DC : CR	500	0.01 %		
<i>AINMODE</i>				
AINMODE	EASY	-	Input scaling mode	
AIN : I	$I = W X V$		Free scaling of the analogue inputs (MATH)	
	A: 1000	-		
	B: 1000	-		
	C: 0	0.01 %		
	X: V	-		

## 5.2 Configuration

### 5.2.1 LG (Changing the language)

Command	Parameters	Unit	Group
LG            x	x= DE   EN	-	STD

Either German or English can be selected for the help texts.



**CAUTION:** After changing the language settings, the ID button (SPEED BUTTON) in the menu bar (WPC-300) must be pressed (module identification).

### 5.2.2 MODE (Switching between parameter groups)

Command	Parameters	Unit	Group
MODE        x	x= STD   EXP	-	STD

This command changes the operating mode. Various commands (defined via STD/EXP) are blanked out in Standard Mode. The commands in Expert Mode have a more significant influence on system behavior and should accordingly be changed with care.

### 5.2.3 SENS (monitoring of the modul functions)

Command	Parameters	Unit	Group
SENS        x	x= ON   OFF   AUTO	-	STD

This command is used to activate/deactivate the monitoring functions (4... 20 mA sensors, output current, signal range and internal failures) of the module.

ON: All monitoring functions are active. Detected failures can be reset by deactivating the ENABLE input.

OFF: No monitoring function is active.

AUTO: Auto reset mode. All monitoring functions are active. If the failure doesn't exist anymore, the module automatically resumes to work.



Normally the monitoring functions are always active because otherwise no errors are detectable via the READY output. Deactivating is possible mainly for troubleshooting.

## 5.2.4 EOUT (Output signal: READY = OFF)

Command	Parameters	Unit	Group
EOUT      x	x= -10000... 10000	0.01 %	EXP

Output value in case of a detected error or a deactive ENABLE input. A value (degree of valve opening) for use in the event of a sensor error (or the module is disabled) can be defined here. This function can be used if, for example, the drive is to move to one of the two end positions (at the specified speed) in case of a sensor error.

$|EOUT| = 0$  The output is switched off in the event of an error. This is normal behavior.



**CAUTION!** If the output signal is 4... 20 mA, the output is switched off when  $|EOUT| = 0$ . If a null value = 12 mA is to be output in the event of an error, EOUT must be set to 1<sup>1</sup>.

The output value defined here is stored permanently (independently of the parameter set). The effects should be analyzed by the user for each application from the point of view of safety.

Do not use the manual mode in conjunction with the EOUT command. After the deactivation of the HAND input the output is set to the EOUT value.

## 5.2.5 HAND (Manual speed)

Command	Parameters	Unit	Group
HAND:i      x	i= A B x= -10000... 10000	0.01%	STD

The manual speeds are set with these parameters. The drive moves in a controlled manner in the defined direction when the manual signal is active. The direction is defined by the sign of the parameters. After the manual signal has been disabled, the drive remains under control in the current position.

In case of a fault (position sensor fault), the drive can still be moved with the manual function. The output will be switched off when hand signals are turned off.

The manual speed is also limited by the (internal or external) speed demand (MIN evaluation).



**Caution!** Do not use the manual mode in conjunction with the EOUT command. After the deactivation of the HAND input the output is set to the EOUT value.

<sup>1</sup> This is necessary if using valves without error detection for signals lower than 4 mA. If the valve has an error detection, it moves into a defined position after switching off the output.

## 5.2.6 INPOS (In position range)

Command	Parameters	Unit	Group
INPOS x	x= 2... 200000	µm	STD

This parameter is entered in µm.

The INPOS command defines a range for which the INPOS message is generated. This function monitors the failure between the command and actual position. If the failure is less than the programmed value a INPOS message at the status output (see Pin description). The positioning process is not influenced by this message. PIN 7 (START) muss be acivated to generate the INPOS messages.

## 5.3 Signal adaptation

### 5.3.1 SYS\_RANGE (Working stroke)

Command	Parameters	Unit	Group
SYS_RANGE x	x= 10... 10000	mm	STD

This command defines the full stroke, which corresponds to 100 % of the input signal. If the demand is set incorrectly, this leads to incorrect system settings, and the dependent parameters such as speed and gain cannot be calculated correctly.

### 5.3.2 SIGNAL (Type of input)

Command	Parameter	Unit	Group
SIGNAL:i x	i= W X V x= OFF U0-10 U10-0 I4-20 I20-4	-	EASY

This command can be used to change the type of input signal (voltages or current) and to define the direction of the signal. This command is available for all analogue inputs (W, X, and V).  
 OFF= Deactivation of the input<sup>2</sup>.

<sup>2</sup> The deactivation can be used to deactivate the velocity (speed) input PIN\_9/10 (the VELO value is active).

### 5.3.3 N\_RANGE:X (Nominal range of the sensor)

Command	Parameter	Unit	Group
N_RANGE:X x	x= 10... 10000	mm	EASY

N\_RANGE (nominal range or nominal stroke) is used to define the length of the sensor. This value should be always higher than SYS\_RANGE. The control parameter cannot be calculated correctly in case of wrong values.

### 5.3.4 OFFSET:X (Sensor offset)

Command	Parameter	Unit	Group
OFFSET:X x	x= -100000... 100000	$\mu\text{m}$	EASY

Adjustment of the zero point of the sensor.

## 5.3.5 Using of the commands `SYS_RANGE`, `N_RANGE:X` and `OFFSET:X`

The application scaling will be done by these three commands. In this example the system is defined by a length of 120 mm of the sensor, a working stroke of 100 mm of the cylinder and an offset of 5 mm. These parameters have to be typed in and the axis is driving between 5 mm and 105 mm of the sensor stroke and between 0 mm and 100 mm of the cylinder stroke.

Correct scaling:

`SYS_RANGE` = 100 (mm)

`N_RANGE:X` = 120 (mm)

`OFFSET:X` = -5000 ( $\mu\text{m}$ )

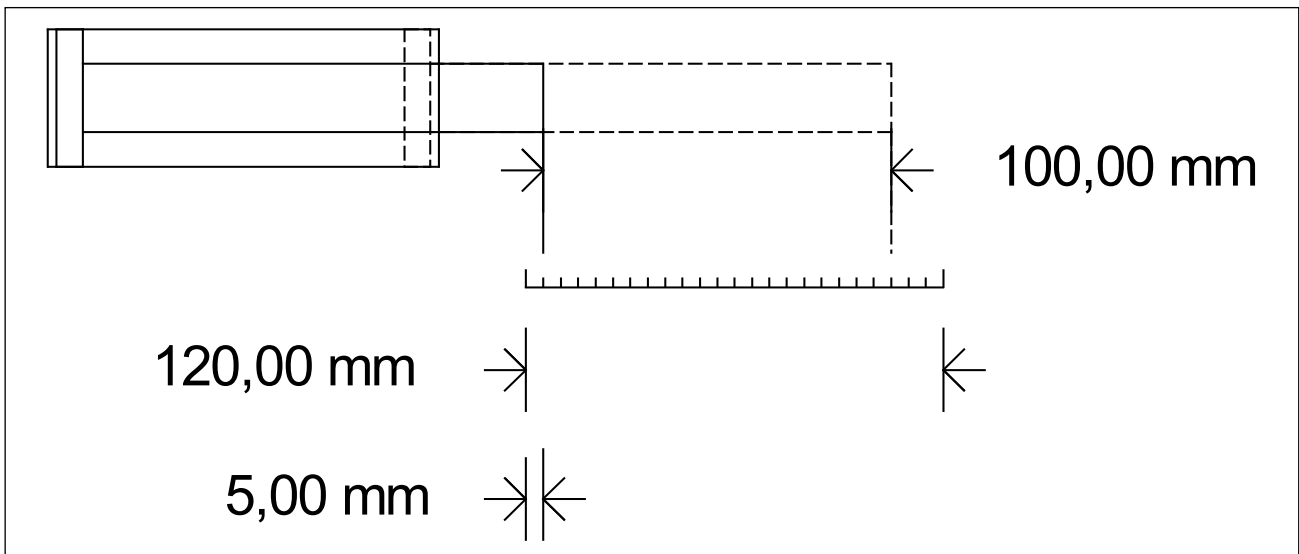

Figure 1 (Input scaling of the sensor)

## 5.4 Speed commands

The SIGNAL:V command is used to switch over between external or internal speed limitation.

SIGNAL:V = OFF      Internal speed limitation (VELO command)

SIGNAL:V = U0-10    External speed limitation

PIN 9/10 is used for external speed limitation<sup>3</sup>.

### 5.4.1 VELO (Internal speed demand value)

Command	Parameters	Unit	Group
VELO      x	x= 1... 10000	0.01 %	SIGNAL:V = OFF

Specification of the internal speed limitation.

### 5.4.2 VRAMP (Ramp time for external speed demand)

Command	Parameters	Unit	Group
VRAMP    x	x= 10... 5000	ms	SIGNAL:V

The rate of change of the external speed demand can be limited by this ramp time. The command is only active if external speed demand (SIGNAL:V <> OFF) has been parameterized.

<sup>3</sup> The output signal is directly limited in SDD mode (default mode). In NC mode the speed profile of the generator is limited. The lowest adjustable speed is 0,01 mm/s (VMAX = 1 mm/s and VELO = 1 %).

## 5.5 Profile generator

### 5.5.1 VMODE (Methode of positioning)

Command	Parameters	Unit	Group
VMODE	x	x= SDD   NC	EXP

The fundamental control structure can be changed with this parameter.

**SDD:** **Stroke-Dependent Deceleration.** In this mode, stroke-dependent deceleration is activated. This mode is the default mode and is suitable for most applications. With stroke-dependent deceleration the drive comes to a controlled stop at the target position. From the deceleration setpoint the drive then switches to closed loop control mode and moves accurately to the desired position. This control structure is very robust and reacts insensitively to external influences such as fluctuating pressures. One disadvantage is that the speed varies with the fluctuating pressure as the system runs under open-loop control.

**NC:** **Numerically Controlled.** In this mode a position profile is generated internally. The system always works under control and uses the following error to follow the position profile. The magnitude of the following error is determined by the dynamics and the closed loop gain. The advantage is that the speed is constant (regardless of external influences) due to the profile demand. Because of continuous control, it is necessary not to run at 100 % speed, as otherwise the errors cannot be corrected. 70... 80 % of the maximum speed is typical although especially the system behavior and the load pressure should be taken into account when specifying the speed.

### 5.5.1 ACCEL (Acceleration in NC mode)

Command	Parameters	Unit	Group
ACCEL	x	x= 1... 20000	mm/s <sup>2</sup> VMODE=NC

This command is used to define the acceleration in NC mode. The command is only active if the VMODE has been parameterized to NC.

### 5.5.2 VMAX (Maximum speed in NC mode)

Command	Parameters	Unit	Group
VMAX	x	x= 1... 2000	mm/s VMODE=NC

Specification of the maximum speed in NC mode. This value is defined by the drive system and should be specified as precisely as possible (not too high under any circumstances). The speed is scaled by means of the VELO value or via the external speed demand. The command is only active if the VMODE has been parameterized to NC.

## 5.6 Control parameter

### 5.6.1 A (Acceleration (ramp) time)

Command	Parameters	Unit	Group
A:i            x	i= A B x= 1... 5000	ms	VMODE=SDD

Ramp function for the 1<sup>st</sup> and 3<sup>rd</sup> quadrants.

The acceleration time for positioning is dependent on the direction. "A" corresponds to connection 15 and "B" corresponds to connection 16 (if POL = +).

Normally A = flow P-A, B-T and B = flow P-B, A-T.

For quadrants 2 and 4, parameters D:A and D:B are used as the deceleration distance demand.

### 5.6.2 D (Deceleration / braking distance)

Command	Parameters	Unit	Group
D:i            x	i= A B S x= 1... 10000	mm	VMODE = SDD

This parameter is specified in mm<sup>4</sup>.

The deceleration stroke is set for each direction of movement (A or B). The control gain is calculated internally depending on the deceleration distance. The shorter the deceleration distance, the higher the gain. A longer deceleration distance should be specified in the event of instability.

Parameter D:S is used as the stopping ramp when disabling the START signal. After disabling, a new target position (current position plus D:S) is calculated in relation to the speed and is specified as a command value.

$$G_{Intern} = \frac{STROKE}{D_i} \quad \text{Calculation of control gain}$$



**CAUTION:** If the maximum stroke (SYS\_RANGE command) is changed, the deceleration distance must also be adjusted. Otherwise this can result in instability and uncontrolled movements.

<sup>4</sup> **CAUTION!** In older modules this parameter was specified in % of the maximum stroke. Since data specification for this module has now been converted to mm, the relationship between the stroke (SYS\_RANGE command) and these parameters must be taken into account.

## 5.6.3 $V_0$ (Loop gain setting)

Command	Parameters	Unit	Group
V0:i      x	i= A B x= 1... 400	s <sup>-1</sup>	VMODE = NC

This parameter is specified in s<sup>-1</sup> (1/s).

In NC Mode normally the loop gain is specified rather than the deceleration stroke<sup>5</sup>.

The internal gain is calculated from this gain value together with the parameters VMAX and SYS\_RANGE.

$$D_i = \frac{v_{\max}}{V_0}$$

Calculation of the internal control gain

$$G_{Intern} = \frac{STROKE}{D_i}$$

In NC Mode the following error at maximum speed is calculated by means of the loop gain. This following error corresponds to the deceleration stroke with stroke-dependent deceleration. The conversion and therefore also the correct data demands related to the closed loop control system are relatively simple if the relationship described here is taken into account.

## 5.6.4 V0:RES (Scaling of the loop gain)

Command	Parameters	Unit	Group
V0:RES    x	x= 1 100	-	VMODE = NC

V0:RES = 1    loop gain in s<sup>-1</sup> (1/s) units.

V0:RES = 100 loop gain in 0.01 s<sup>-1</sup> units<sup>6</sup>.



The increased resolution should be used in case of  $V_0 < 4$ .

<sup>5</sup> The loop gain is alternatively defined as a KV factor with the unit (m/min)/mm or as  $V_0$  in 1/s. The conversion is  $KV = V_0/16,67$ .

<sup>6</sup> In case of very low loop gains (1 s<sup>-1</sup> to 3 s<sup>-1</sup>) the better resolution of the adjustment should be selected.

## 5.6.5 PT1 (Timing of the controller)

Command	Parameter	Unit	Group	
PT1	x	x= 0... 300	ms	EXP

This parameter can be used to change the internal timing of the control function. Hydraulic drives are often critical to control especially in case of high speeds and very fast valves. The PT1 filter can be used to improve the damping rate and allows therefore higher loop gains. Requirements for the use are: The natural frequency of the valve should be equal or higher than the natural frequency of the drive.

## 5.6.6 CTRL (Deceleration characteristics)

Command	Parameters	Unit	Group	
CTRL	x	x= LIN   SQRT1   SQRT2	-	STD

The deceleration characteristic is set with this parameter. In case of positively overlapped proportional valves the SQRT function should be used. The non-linear flow function of these valves is linearized by the SQRT<sup>7</sup> function.

In case of zero lapped valves (control valves and servo valves) the LIN or SQRT1 function should be used regardless of the application. The progressive characteristic of the SQRT1 function has better positioning accuracy but can also lead to longer positioning times in individual cases.

**LIN:** Linear deceleration characteristic (gain is increased by a factor of 1).

**SQRT1:** Root function for braking curve calculation. The gain is increased by a factor of 3 (in the target position). This is the default setting.

**SQRT2:** Root function for braking curve calculation. The gain is increased by a factor of 5 (in the target position). This setting should only be used with a significantly progressive flow through the valve.

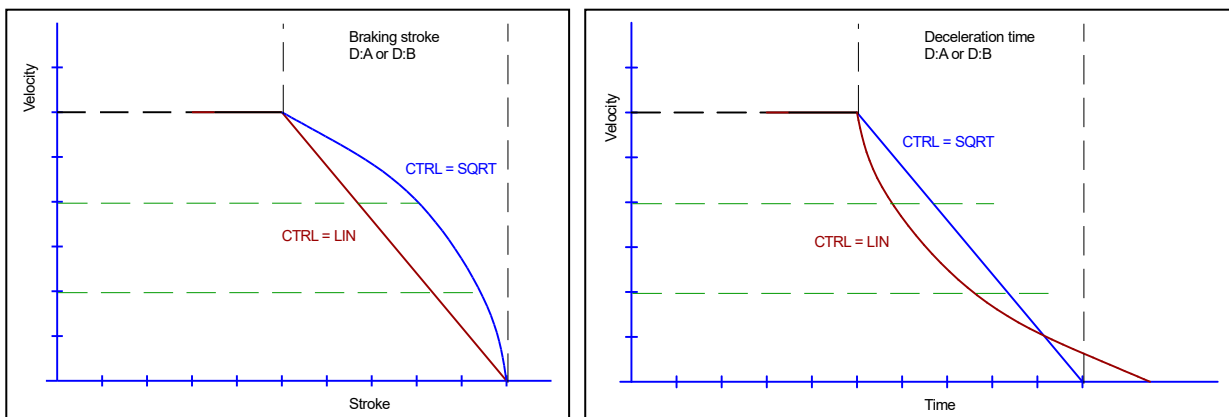

**Figure 2 (Braking function with respect to stroke and time)**

<sup>7</sup> The SQRT function generates constant deceleration and thus reaches the target position faster. This is achieved by increasing the gain during the deceleration process.

## 5.7 Output signal adaptation

### 5.7.1 MIN (Deadband compensation)

### 5.7.2 MAX (Output scaling)

### 5.7.3 TRIGGER (Response threshold for the MIN parameter)

Command	Parameters	Unit	Group
	$i = A   B$	-	STD
MIN:i	x	x= 0... 6000	0.01 %
MAX:i	x	x= 3000... 10000	0.01 %
TRIGGER	x	x= 0... 4000	0.01 %

The output signal to the valve is adjusted by means of these commands. A kinked volume flow characteristic is used instead of the typical overlap step for the position controls. The advantage is better and more stable positioning behavior. At the same time, kinked volume flow characteristics can also be adjusted with this compensation<sup>8</sup>.



**CAUTION:** If there should also be adjustment options for deadband compensation on the valve or valve amplifier, it must be ensured that the adjustment is performed either at the power amplifier or in the module.

If the MIN value is set too high, this has an effect on the minimum speed, which can then no longer be adjusted. In extreme cases this leads to oscillation around the the controlled position.

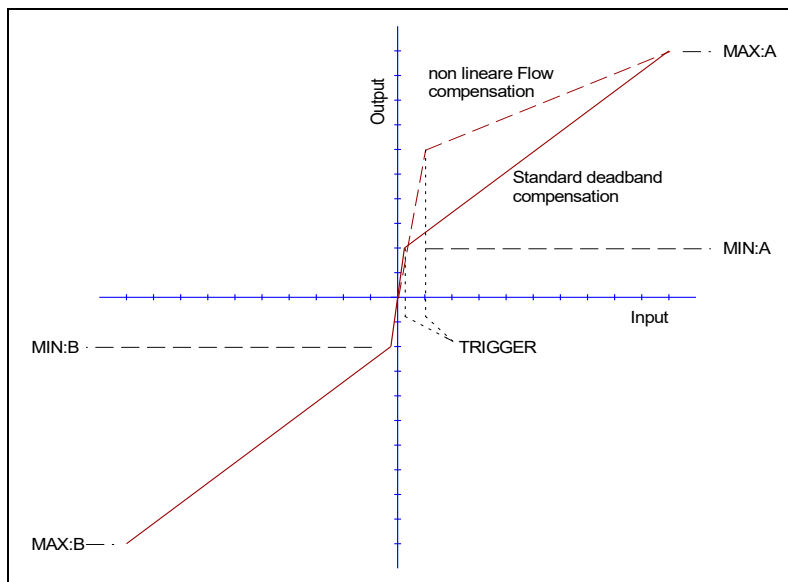

<sup>8</sup> Various manufacturers have valves with a defined nonlinear curve: e.g. a kink at 40 or 60 % (corresponding to 10 % input signal) of the nominal volume flow. In this case the TRIGGER value should be set to 1000 and the MIN value to 4000 (6000).

If zero lapped or slightly underlapped valves are used, the volume flow gain in the zero range (within the underlap) is twice as high as in the normal working range. This can lead to vibrations and jittery behavior. To compensate this, the TRIGGER value should be set to approximately 200 and the MIN value to 100. The gain in the zero point is thus halved and an overall higher gain can often be set.

## 5.7.4 OFFSET (Zero correction)

Command	Parameters	Unit	Group
OFFSET x	x= -4000... 4000	0.01 %	STD

This parameter is entered in 0,0 1% units.

The offset value is added to the output value. Valve zero offsets can be compensated with this parameter.

## 5.7.5 SIGNAL:U (Type and polarity of the output signal)

Command	Parameter	Unit	Group
SIGNAL:U x	x= U+-10 I4-12-20 U-+10 I20-12-4	-	EXP

This command is used to define the output signal (voltage or current) and to change the polarity<sup>9</sup>.

Differential output  $\pm 100\%$  corresponds with  $\pm 10\text{ V}$  (0... 10 V at PIN 15 and PIN 16).

Current output  $\pm 100\%$  corresponds with 4... 20 mA (PIN 15 to PIN 12). 12 mA (0 %) = center point of the valve.



An output current of  $\ll 4\text{ mA}$  indicates an error and the module is disabled. The current input of the proportional valves should be monitored by the valve. The valve have to be deactivated in case of  $< 4\text{ mA}$  input signal. Otherwise the EOUT command can be used to get a defined output signal.

<sup>9</sup> The older POL command is removed.

## 5.8 Special commands

### 5.8.1 Drift compensation / high accurate positioning

The high accurate positioning or the drift compensation can be used in case of external influence which is limiting the positioning accuracy. This function could be critical if limit cycling<sup>10</sup> by wrong parameterization or the system behavior was not taken into account.

Which positioning errors can be compensated<sup>11</sup>?

1. Zero point adjustment of the valve. By this kind of failure a constant offset between command and feedback signal remains. This failure is more or less constant.
2. Zero point failure depending on the temperature. The same behavior as point 1, but the failure is increasing slowly (over the temperature).
3. Position failure caused by an external force. All control and servo valves have a typical pressure gain characteristic. In case of external forces an output signal of 2...3 % has to be generated for the compensation of this force. And this signal is proportional to the positioning error. In opposite to point one and two the positioning failure generated by the force signal can vary cycle to cycle.

How does it work?

The position errors should be compensated when the axis is near by the target position. The output signal is going lower and lower but a system specific position error remains. At the activation point this function – a slowly working integrator – is active. This integrator signal is added to the output signal and will compensate offsets and other failure. To prevent instabilities, the integrator value will be frozen when the output value is lower than the deactivation point.

#### **Drift compensation (to compensate failure of the zero point adjustment)**

To compensate position errors of point one and two.

#### **High accurate positioning (used at external forces or general drift compensation)**

To compensate positions errors of point three. Alternatively of point one, two and three.

#### **Positioning modules without fieldbus:**

Only one function is implemented to compensate the positioning error of point one, two and three. The activation is controlled by the parameterization of DC:AV parameter.

#### **Positioning modules with fieldbus:**

Two functions are implemented to compensate offset/temperature dependent and/or force dependent positioning errors<sup>12</sup>. The activation is controlled by the parameterization of DC:AV parameter and the following fieldbus control bits:

- DC\_ACTIVE:** General activation of the drift compensation and high accurate positioning.
- DC\_FEEZE:** Freezing of the static drift compensation value.
- F\_POS:** Activation of the high accurate positioning (dynamic drift compensation).

<sup>10</sup> The „limit cycling“ is a small and permanent oscillation around the target position. The main reason are static frictions and the hysteresis of the valve. By proper parameter setting, this can be avoided under the boundary condition that the desired accuracy is not achieved. In this case, the hydraulic system is the limiting factor in the accuracy.

<sup>11</sup> This is relevant for zero lapped control valves and servo valves.

<sup>12</sup> To prevent / minimize position overshoots the static drift compensation have to be done first.

## Typical setup

Valve pressure gain: 2,5 %; the activation point has to be set to 3... 5 % (DC:AV 300... 500).

Valve hysteresis: 0,5 %; the deactivation point has to be set to 0,7... 1,0 % (DC:DV 70... 100). The lower the value the better the accuracy.

DC:CR should be equal to DC:AV.

The optimum integrator time has to be determined experimentally. Starting with higher values is recommended.

### 5.8.1.1 DC:AV (Activation value)

### 5.8.1.2 DC:DV (Deactivation value)

### 5.8.1.3 DC:I (Integrator time )

### 5.8.1.4 DC:CR (Integrator limitation)

Command	Parameter	Unit	Group	
DC:AV	x	x= 0... 2000	0.01 %	EXP
DC:DV	x	x= 0... 1000	0.01 %	
DC:I	x	x= 0... 2000	ms	
DC:CR	x	x= 0... 500	0.01 %	

DC:AV This parameter is used to define the activation point (activation value). The DC function is completely deactivated in case of DC:AV = 0.

DC:DV This parameter is used to define the deactivation point (DV = deactivation value) Within the deactivation window no compensation value will be calculated (frozen state). DC:AV = 0 should be used for best positioning, but „limit cycling“ can occur. This value should be set to 50 % of an acceptable error.

DC:I This parameter is used to define the integrator time. The lower this value the faster the compensation. Low values will result in „limit cycling“.

DC:CR The output range of the DC function will be limited (CR = control range) by this parameter.

## 5.8.2 AINMODE

The AINMODE is used to define the kind of parameterizing of the analogue inputs. The EASY mode (DEFAULT) supports a simple and application oriented input scaling.

The MATH mode supports the free input scaling by a linear equation. This mode is compatible to our older modules.



Attention: This command can be executed in the terminal window only. In case of switching back, DEFAULT data should be reloaded.

### 5.8.2.1 AINMODE (Input scaling mode)

Command	Parameter	Unit	Group
AINMODE <b>x</b>	<b>x= EASY   MATH</b>	-	STD

This command is used to switch over the kind of input scaling.

### 5.8.2.2 AIN (Analogue input scaling)

Command	Parameters	Unit	Group
AIN: <b>i</b>	<b>i= W   X   V</b>		<b>MATH</b>
<b>A</b>	<b>a= -10000... 10000</b>	-	
<b>B</b>	<b>b= -10000... 10000</b>	-	
<b>C</b>	<b>c= -10000... 10000</b>	0.01 %	
<b>X</b>	<b>x= V   C</b>	-	

This command can be used to scale the individual inputs. The following linear equation is used for scaling.

$$Output = \frac{a}{b} (Input - c)$$

The "c" value is the offset (e. g. to compensate the 4 mA in case of a 4... 20 mA input). The variables "a" and "b" define the gain factor.

e.g.: 2.345 correspond to: **a** = 2345, **b** = 1000

The internal measuring resistor for measuring the current (4... 20 mA) is activated via the **x** value and the evaluation switched over accordingly.

## Typical settings:

Command	Input	Description
<b>AIN:X</b> 1000 1000 0 V	0... 10 V	Range: 0... 100 %
<b>AIN:X</b> 10 8 1000 V OR <b>AIN:X</b> 1000 800 1000 V	1... 9 V	Range: 0... 100 %; 1 V = 1000 used for the offset and gained by 10 / 8 (10 V divided by 8 V (9 V -1 V))
<b>AIN:X</b> 10 4 500 V OR <b>AIN:X</b> 1000 400 500 V	0.5... 4.5 V	Range: 0... 100 %; 0,5 V = 500 used for the offset and gained by 10 / 4 (10 V divided by 4 V (4.5 V -0.5 V))
<b>AIN:X</b> 20 16 2000 C OR <b>AIN:X</b> 2000 1600 2000 C OR <b>AIN:X</b> 1250 1000 2000 C	4... 20mA	Range: 0... 100 % The offset will be compensated on 20 % (4 mA) and the signal (16 mA = 20 mA – 4 mA) will be gained to 100 % (20 mA). Each of this parameterization for 4... 20 mA is setting the range to 0... 100 %.

## 5.9 Process data

Command	Description	Unit
<b>WA</b>	Demand value (input signal)	mm
<b>W</b>	Demand value (according to the profile generator)	mm
<b>V</b>	Speed input	%
<b>X</b>	Actual value	mm
<b>E</b>	Error value	mm
<b>C</b>	Output of the controller	%
<b>U</b>	Output signal of the module	%
<b>IA</b>	Solenoid current A	mA (P Version only)
<b>IB</b>	Solenoid current B	mA (P Version only)

The process data are the variables which can be observed continuously on the monitor or on the oscilloscope.

## 6 Appendix

### 6.1 Failure monitoring

Following possible error sources are monitored continuously when SENS = ON/AUTO:

Source	Fault	Characteristic
Command signal PIN 13 4... 20 mA	Out of range or broken wire	The output will be switched off.
Feedback signal PIN 14 4... 20 mA	Out of range or broken wire	The output will be switched off.
<b>SSI-VERSION</b> Sensor value	Out of range or broken wire	The output will be switched off.
<b>P-VERSION</b> Solenoids on PIN 17-20	Wrong cabling, broken wire	The power stage will be deactivated.
EEPROM (when switching on)	Data error	The output is deactivated. The module can only be activated by saving the parameters again!



**CAUTION:** Take care of the EOUT command. Changes will influence the behavior.

### 6.2 Troubleshooting

It is assumed that the device is in an operable state and there is communication between the module and the WPC-300. Furthermore, the valve control parameterization has been set with the assistance of the valve data sheets.

The RC in monitor mode can be used to analyze faults.



**CAUTION:** All safety aspects must be thoroughly checked when working with the RC (Remote Control) mode. In this mode the module is controlled directly and the machine control cannot influence the module.

FAULT	CAUSE / SOLUTION
ENABLE is active, the module does not respond and the READY LED is off.	There is presumably no power supply or the ENABLE signal (PIN 8) is not present. If there is no power supply, there is also no communication via our operating program. If a connection has been made to the WPC-300, then a power supply is also available.  If the power supply exists, an attempt should be made to see whether the system can be moved by means of the HAND+ and HAND- inputs (measuring the output signal to the valve helps).

FAULT	CAUSE / SOLUTION
ENABLE is active, the READY LED is flashing.	<p>The flashing READY LED signals that a fault has been detected by the module. The fault could be:</p> <ul style="list-style-type: none"> <li>• A broken cable or no signal at the input (PIN 13 or PIN 14), if 4... 20 mA signals are parameterized.</li> <li>• A broken cable or incorrect cabling to the solenoids (in the P version only).</li> <li>• SSI sensor</li> <li>• Internal data error: press the command/SAVE button to delete the data error. The system reloads the DEFAULT data.</li> </ul> <p>With the WPC-300 operating program the fault can be localized directly via the monitor.</p>
ENABLE is active; the READY LED is on, the system moves to an end position.	<p>The control circuit polarity is incorrect. The polarity can be changed with the POL command or by reversing the connections to PIN 15 and PIN 16.</p>
ENABLE is active, the READY LED is on, the STATUS LED is not on, the system moves to the target position but doesn't reach it (positioning error).	<p>Serious positioning errors can result from incorrect parameterization or incorrect system design.</p> <ul style="list-style-type: none"> <li>• Is the cylinder position specified correctly?</li> <li>• Are the deceleration strokes correct (to start the system the deceleration distances should be set to approx. 20... 25 % of the cylinder position<sup>13</sup>)?</li> <li>• Is the valve a zero lapped control valve or a standard proportional valve? In the case of a proportional valve, the valve overlap which may be present should be compensated for with the MIN parameters. Typical values are to be found in the valve data sheet.</li> </ul>
ENABLE is active, the READY LED is on, and the system oscillates on the target.	<p>The system is working and also actuating the valve.</p> <p>Various potential problems could be:</p> <ul style="list-style-type: none"> <li>• The parameterization is not yet adjusted to the system (gain too high).</li> <li>• There is severe interference on the power supply.</li> <li>• Very long sensor cables (&gt; 40 m) and sensor signal interference.</li> <li>• The MIN setting to compensate the valve overlap is too high.</li> </ul> <p>As a basic principle, the parameterization of the sensor data and the controller settings must be carried out first (before switching on). An incorrect demand is equivalent to incorrect system design which then leads to incorrect operation. If the system oscillates, the gain should first be reduced (longer deceleration distances for D:A and D:B) and in the case of overlapped valves the MIN parameter should also be reduced.</p>
Speed too low	<p>The drive may be able to move to position but the speed is too low.</p> <ul style="list-style-type: none"> <li>• Check the control signal to the valve. <ul style="list-style-type: none"> <li>• Via the integrated oscilloscope (U variable).</li> <li>• Measure the signal to the valve with an external oscilloscope / voltmeter.</li> </ul> </li> <li>• If the control is within the range of <math>\pm 100\%</math> (<math>\pm 10\text{ V}</math>), the fault must be sought in the hydraulics.</li> <li>• If the control signal is relatively low, the following points should be checked: <ul style="list-style-type: none"> <li>• Is the internal/external speed signal limiting the speed?</li> <li>• Which setting has been specified for the deceleration distance in relation to the POSITION?</li> </ul> </li> </ul>
Speed too high	<p>The drive should move to position. The drive moves in and out too fast leading to uncontrolled behavior. Reducing the speed (MAX or VELO parameter) has very little or no effect.</p> <ul style="list-style-type: none"> <li>• The hydraulic system is over-sized. The entire parameterization of the movement cycle cannot be reproduced (overlap and deceleration distance settings)</li> </ul>

<sup>13</sup> The stability criterion of the hydraulic axes must be taken into account.

## 6.3 Description of the command structure

The command structure:

[**nnnn:i x**] or  
[**nnnn x**]

Meaning:

**nnnn** - used for an arbitrary command name

**nnnn:** - used for an arbitrary command name, expandable by an index.

Indexed commands are indicated by the sign “.”

**i** oder **⊖** - is a dummy for the index. E. g. an index can be „A“ or „B“, depending on the direction.

**x** - parameter value, in case of special commands more than one parameter are possible.

### Examples:

MIN:A 2000    nnnn = “MIN”, i = “A” and x = “2000”

OFFSET 50    nnnn = „OFFSET“ and x = „50“

C:IC 2000    nnnn = “C”, i = “IC” and x = “2000”

## 7 ADDITIONAL INFORMATION: Power output stage

### 7.1 General function

The power output stages have been developed for controlling proportional valves without spool position feedback. The output stage is controlled by the microcontroller on the basic module by means of pulse width modulated signals, and the current is continuously controlled. The cycle time for the controller is 0,125 ms.

The output stage can be ideally adjusted to dynamic requirements via internal parameters.

Valve technology: Proportional valves manufactured by REXROTH, BOSCH, DENISON, EATON, PARKER, FLUID TEAM, ATOS and others.

## Features

- Two power output stages with maximum output range up to 2.6 A
- Hardware short-circuit protection with 3  $\mu$ s response time
- Adjustable PWM frequency, dither frequency and dither amplitude
- High current signal resolution
- No additional delay times between the control function and the power stage
- Separate power supply for safety-relevant applications
- Integrated into the standard controller, no additional wiring necessary
- Limitation of the maximum current consumption from the supply, thus a combination with upstream electronic load fuses is possible
- Optimum price/performance ratio

## 7.2 Device description

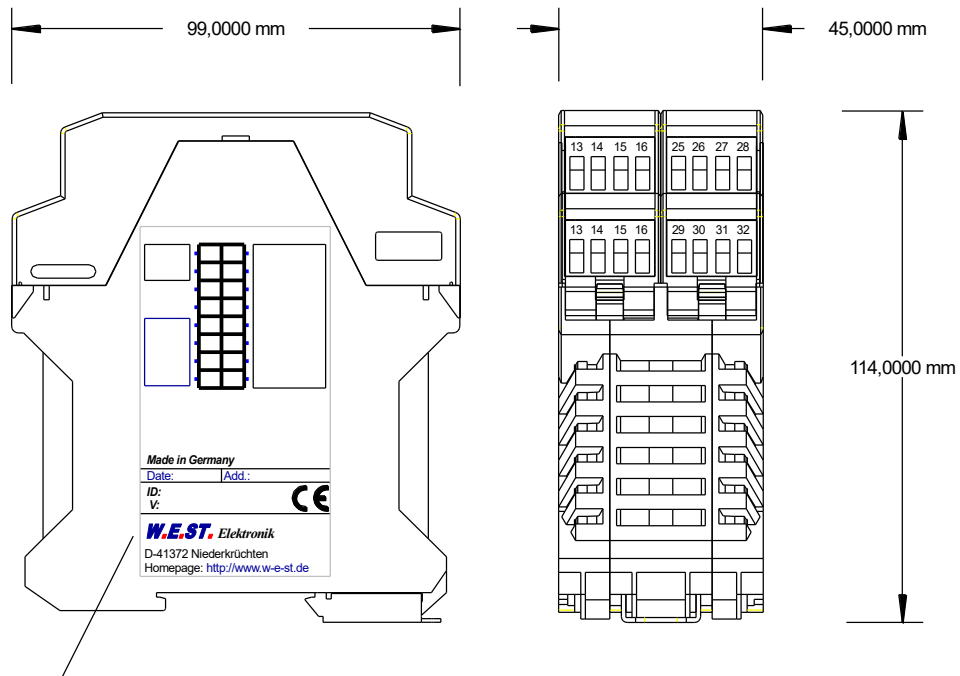

Type plate and terminal pin assignment

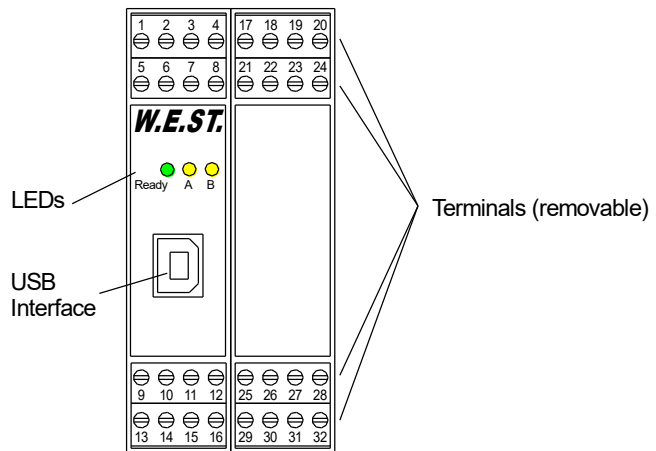

## 7.3 Inputs and outputs

Connection	Signal description
PIN 22 + PIN 24 -	<b>Power supply: 10... 30 VDC:</b> For safety-related applications, the output stage can be deactivated thanks to the separate power supply inputs.
PIN 17 + 19	Solenoid current output A
PIN 18 + 20	Solenoid current output B
Connection	Signals modified from the standard (A and I version)
PIN 15	0... 10 V / 4... 20 mA output with the scaled position demand value
PIN 16	0... 10 V / 4... 20 mA output with the scaled position actual value

## 7.4 Circuit diagram

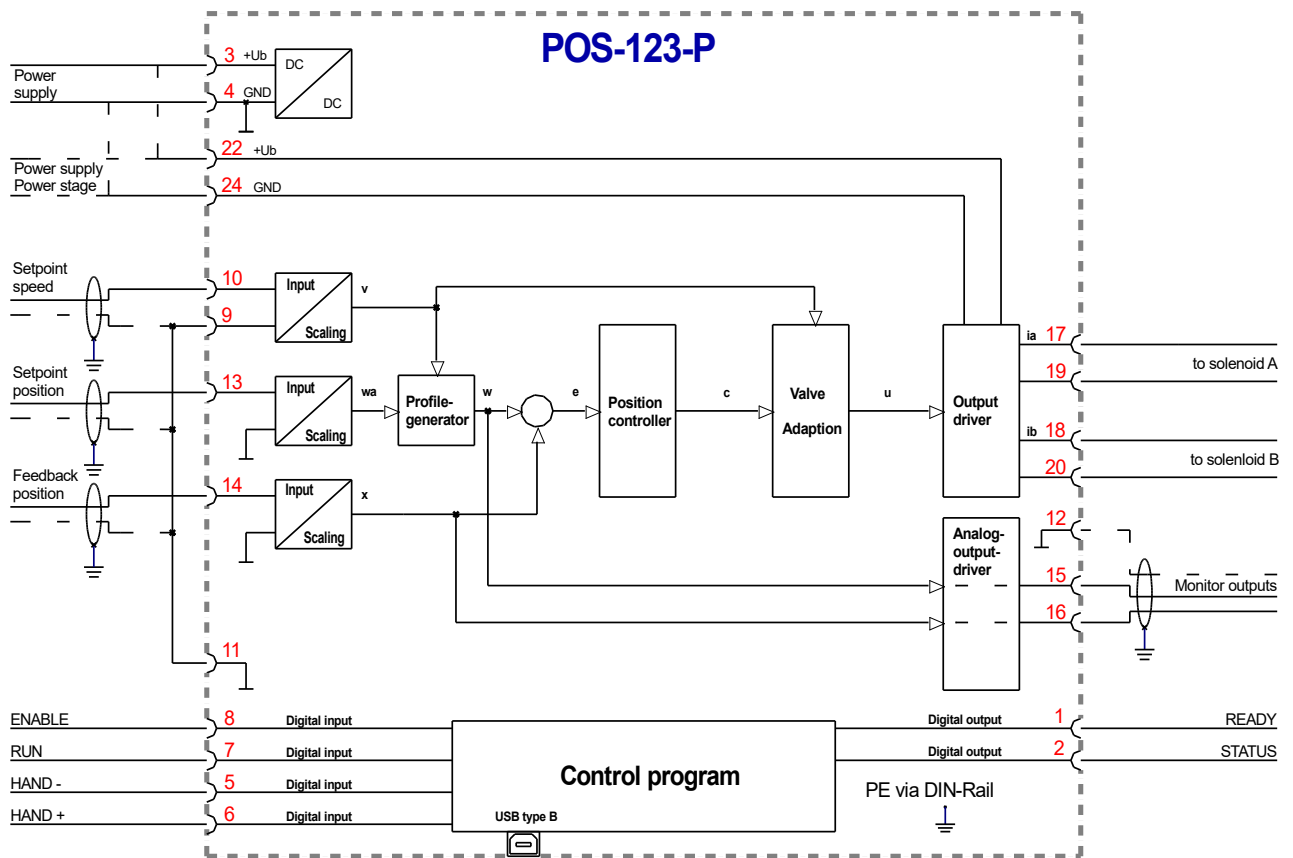

## 7.5 Typical wiring

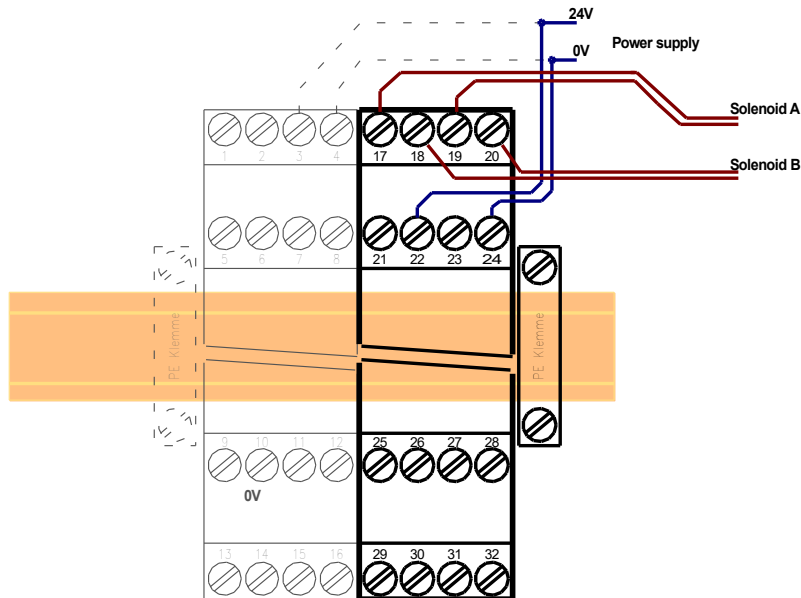

**CAUTION:** The solenoid cables should be screened due to electro-magnetic emissions.

**CAUTION:** plugs with free-wheeling diodes and LED indicators cannot be used with current-controlled power outputs. They interfere with the current control and can destroy the output stage.

## 7.6 Technical data

Supply voltage	<b>[VDC]</b>	12... 30 (incl. ripple)
Power consumption max.	<b>[W]</b>	max. 2.5 and Power of the connected coils
Fuse protection	<b>[A]</b>	3 (medium time lag)
PWM output		Wire break and short circuit monitored
Max. output current	<b>[A]</b>	2.6
Frequency	<b>[Hz]</b>	61... 2604 selectable in defined steps
Sample time solenoid current control	<b>[ms]</b>	0.125
Weight	<b>[kg]</b>	0.25 (incl. standard module)
Connections		
Plug connectors		6 x 4-pole terminal blocks

## 7.7 Parameter overview of the power stage

Command	Default	Unit	Description
SIGNAL:M	V	-	Type of the monitor output signal
SIGNAL:U	+	-	Output polarity
CURRENT	1000	mA	Output current range
DFREQ	121	Hz	Dither frequency
DAMPL	500	0.01 %	Dither amplitude
PWM	2604	Hz	PWM frequency
ACC	ON	-	Automatic calculation of the PPWM and IPWM parameter
PPWM	7	-	Current control loop PI control dynamics
IPWM	40	-	
IMS	2600	mA	Maximum current limitation
SOLERR	ON	-	Function of the wire break monitoring

The standard parameterization has been used with a large number of proportional vales from various manufacturers. This parameterization has proved to be good as long as no special demands concerning the application have to be fulfilled.

## 7.8 Parameter description of the power stage

### 7.8.1 SIGNAL:M (Type of the monitor output signal)

Command	Parameter	Unit	Group
SIGNAL:M x	x= U0-10   I4-20	-	EXP

This command is used to define the output signal (voltage = U0-10 or current = I4-20).

### 7.8.2 SIGNAL:U (Polarity of the output signal)

Command	Parameters	Unit	Group
SIGNAL:U x	x= + -	-	STD

The output polarity is set by this parameter.

## 7.8.3 CURRENT (Rated output current)

Command	Parameters	Unit	Group
CURRENT x	x= 500... 2600	mA	STD

The nominal output current is set. Dither and also MIN/MAX always refer to this current range.

## 7.8.4 DFREQ (Dither frequency)

## 7.8.5 DAMPL (Dither amplitude)

Command	Parameters	Unit	Group
DFREQ x	x= 60... 400	Hz	STD
DAMPL x	x= 0... 3000	0.01 %	STD

The dither<sup>14</sup> can be defined with this commands. Different amplitudes or frequencies may be required depending on the valve.

The dither amplitude is defined in % (peak to peak value) of the nominal output current<sup>15</sup> (see: CURRENT command).

The dither frequency is defined in Hz. Depending on the internal calculations, the frequency is adjustable in steps only<sup>16</sup>.



**CAUTION:** The PPWM and IPWM parameters influence the effect of the dither setting. These parameters should not be altered again after the dither has been optimized.

**CAUTION:** If the PWM frequency is less than 500 Hz, the dither amplitude DAMPL should be set to zero.

## 7.8.6 PWM (PWM Frequenz)

Command	Parameter	Unit	Group
PWM x	x= 61... 2604	Hz	EXP

The frequency can be changed in defined steps (61 Hz, 72 Hz, 85 Hz, 100 Hz, 120 Hz, 150 Hz, 200 Hz, 269 Hz, 372 Hz, 488 Hz, 624 Hz, 781 Hz, 976 Hz, 1201 Hz, 1420 Hz, 1562 Hz, 1736 Hz, 1953 Hz, 2232 Hz and 2604 Hz). The optimum frequency depends on the valve.



**Attention:** The PPWM and IPWM parameters should be adapted when using low PWM frequencies because of the longer dead times which forces a reduced stability of the closed loop control.

<sup>14</sup> The dither is a ripple signal which is superimposed on the current set point and is defined by the amplitude and frequency: the dither frequency and the PWM frequency. The dither frequency should not be confused with the PWM frequency. In some documentations the PWM frequency is described as a dither. This can be recognized by the lack of the dither amplitude.

<sup>15</sup> The dither amplitude is a command signal. Derivations between the commanded amplitude and the real amplitude are possible, depending on the dynamic of the solenoid.

<sup>16</sup> The lower the dither frequency, the smaller the steps. Therefore no practical problems are expected.

## 7.8.7 ACC (Current loop ato adjustment )

Command	Parameter	Unit	Group
ACC      x	x= ON   OFF	-	EXP

Operation mode of the closed loop current control.

- ON:** In automatic mode PPWM and IPWM are calculated depending on the preset PWM-frequency.
- OFF:** Manual adjustment.

## 7.8.8 PPWM (Solenoid current controller P element)

## 7.8.9 IPWM (Solenoid current controller I element)

Command	Parameters	Unit	Group
PPWM      x	x= 0... 30	-	EXP
IPWM      x	x= 4... 100	-	

The PI current controller for the solenoids is parameterized with these commands.



**CAUTION:** These parameters should not be changed without adequate measurement facilities and experience.



**Attention,** if the parameter ACC is set to ON, these adjustments are done automatically.

If the PWM frequency is < 250 Hz, the dynamic of the current controller has to be decreased.  
 Typical values are: PPWM = 1... 3 and IPWM = 40... 80.

If the PWM frequency is > 1000 Hz, the default values of PPWM = 7 and IPWM = 40 should be chosen.

## 7.9 Special Functions

### 7.9.1 IMS (Theoretical maximum current drain)

In order to offer a safe protection against overheating of the coil in case of a hardware failure, the use of an up-stream electronic overload protection may be required.

Further information about this topic can be taken from the document AN-102: „proportional magnet coils in Ex – protection areas”.

With the parameter IMS it is possible to limit the current drain of the power amplifier in a way that even under adverse conditions the overload protection will not trigger if there is no hardware fault. The function does not delimit the dynamics of the system and the full solenoid current is preserved as long as possible. The limiting function calculates the current drain by considering the solenoid current and the duty cycle of the PWM signal. Therefore its precision is affected by the PWM frequency, but it is always sufficient in order to avoid triggering the protection switch.

Preset value of the parameter is 2600 mA and this means it is inactive. Activation of the function is achieved by setting  $IMS < CURRENT$ . The rated current of the protection switch should be entered.

Command	Parameter	Unit	Group
IMS        x	x= 500 ... 2600	mA	EXP

### 7.9.2 SOLERR (Function of the wire break monitoring)

Command	Parameter	Unit	Group
SOLERR    x	x= ON OFF	-	TERMINAL

Reaction when a wire break is detected on the output circuits of the power stages:

**ON:** Wire break is processed as an error and leads to a shutdown of the module  
(SENS = ON or SENS = AUTO)

**OFF:** Wire break is only indicated by the LED display in the monitor window of the WPC.

## 8 ADDITIONAL INFORMATION: SSI interface

### 8.1 General function

This expansion interface is suitable for digital position sensors. The accuracy of the internal processing is 1  $\mu\text{m}$ .

In addition, the digital information is also provided as an analogue position value (0... 10 V for 0... SYS\_RANGE).

## Features

- Digital sensor interface
- Freely parameterization (bit width, code, resolution)
- Safe and error-free data transmission
- 0... 10 V output (current position)

## 8.2 Device description

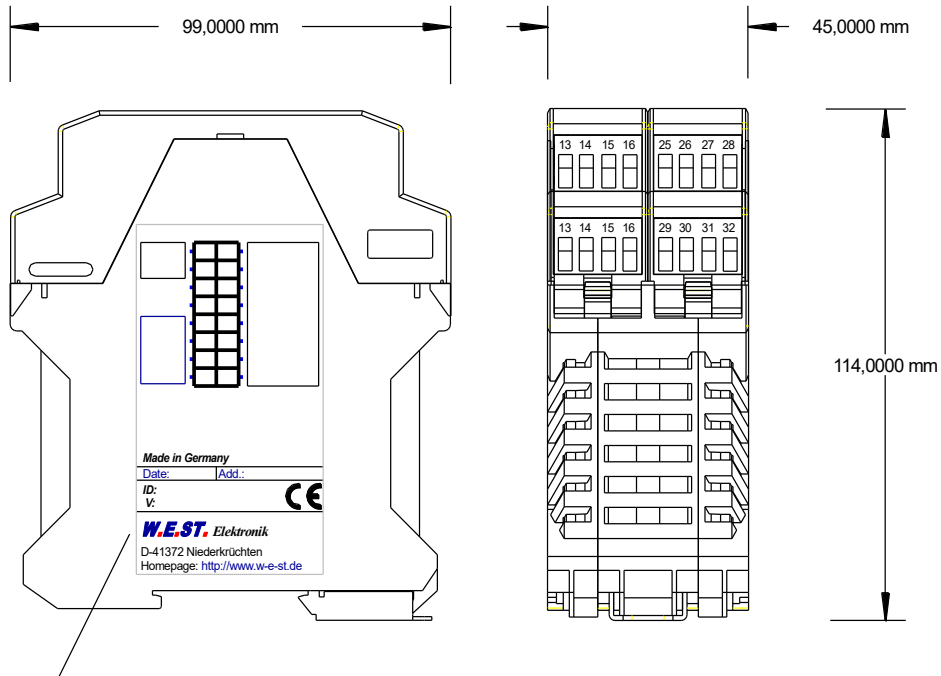

Type plate and terminal pin assignment

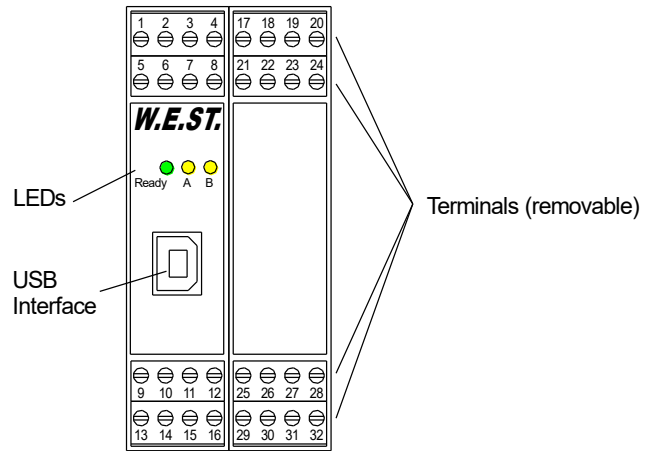

## 8.3 Inputs and outputs

Connection	Signal description
PIN 17	0... 10 V as position reference output*
PIN 19	Power supply (see technical data)
PIN 20	0 V (GND) connection
Connection	SSI Interface (RS422)
PIN 25	CLK +
PIN 26	CLK -
PIN 27	DATA +
PIN 28	DATA -
PIN 31	Supply of the sensor 24 V
PIN 32	Supply of the sensor 0 V

The monitoring output is no precise output. It serves only to provide the actual axis position without being connected via the interface. So it can happen that there are small deviations in relation to the process data displayed in the monitor when connected.

## 8.4 Circuit diagram

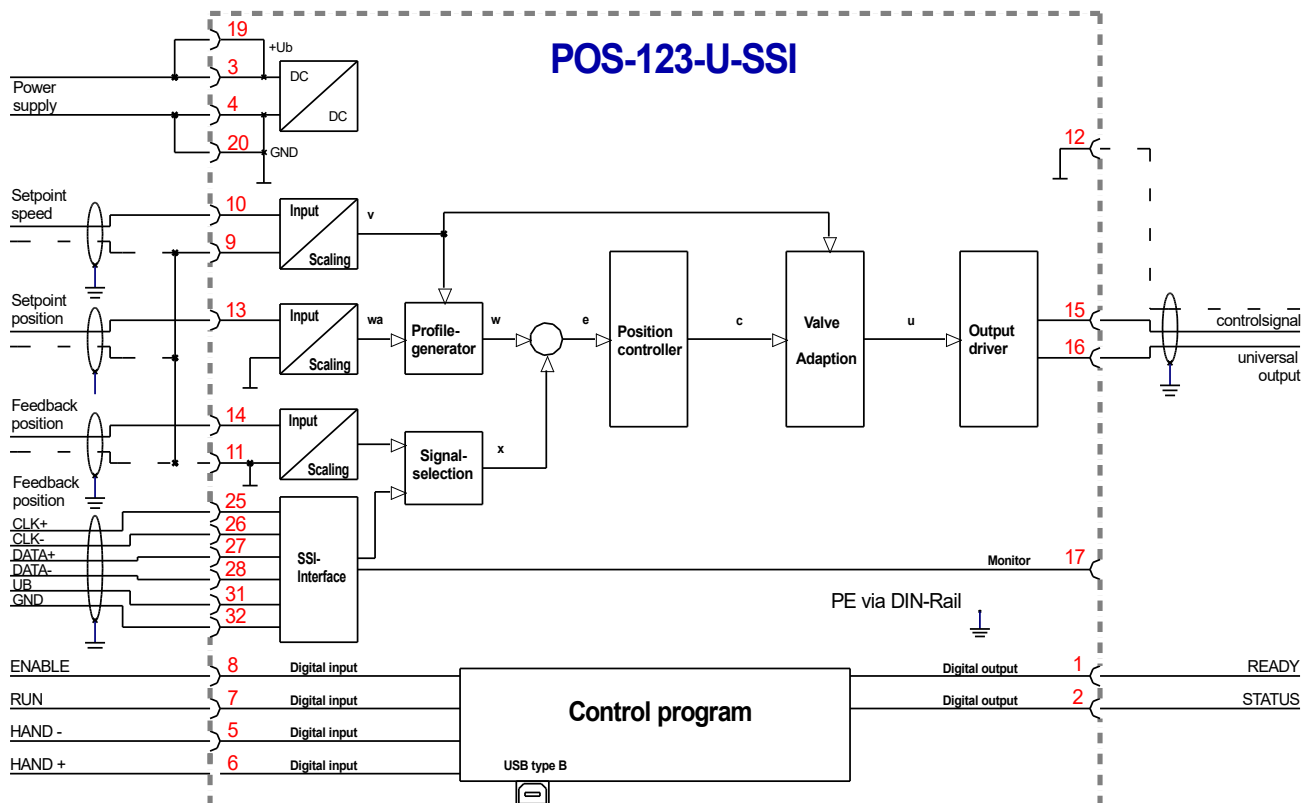



## 8.5 Typical wiring

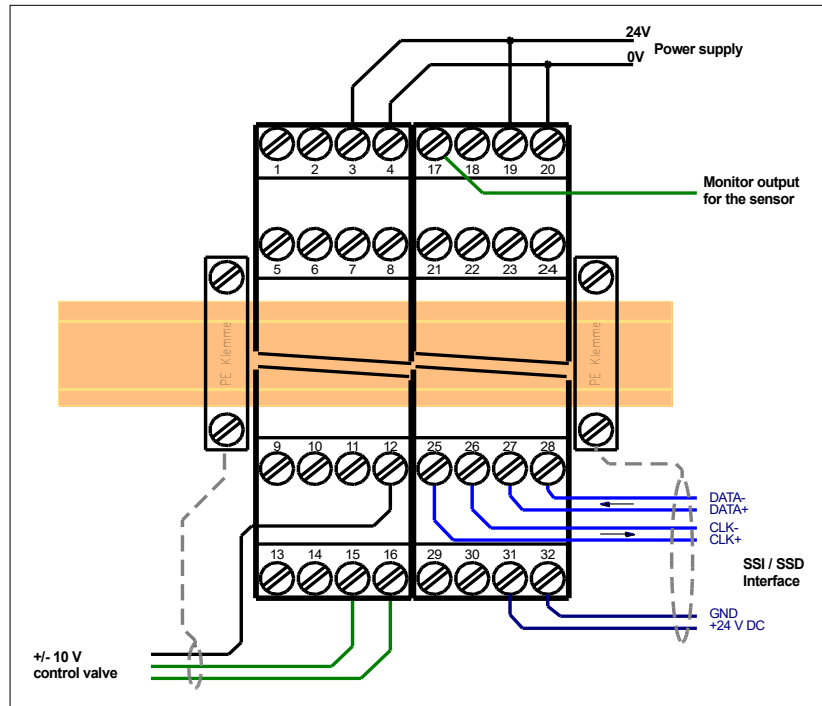

## 8.6 Technical data

Supply voltage (U <sub>b</sub> )	<b>[VDC]</b>	24 (±10 %)
Power consumption	<b>[W]</b>	max. 2.5 without sensor consumption
External protection	<b>[A]</b>	1 medium time lag
SSI interface		
Specification	-	RS-422
Data rate	<b>[kbit/s]</b>	120 kBaud
Weight	<b>[kg]</b>	0.25 (incl. standard module)
Connections		7 x 4-pole terminal blocks



**CAUTION:** For supply voltage and current requirement the technical data of the sensor have to be considered.

## 8.7 Special versions

- S1 (POS-123-U-SSI-S1)  
Special version of the positioning controller with SSI interface:  
The monitoring output on PIN 17 is realized as 4... 20 mA signal.

## 8.8 Parameter overview of the SSI interface

Command	Default	Unit	Description
SELECT:X	SSI	-	Sensor input changeover
SSI:RANGE	100		Working length of the sensor
SSI:OFFSET	0	µm	Position offset
SSI:POL	+	-	Sensor polarity
SSI:RES	100	10 nm	Sensor resolution
SSI:BITS	24	-	Number of bits transmitted
SSI:CODE	GRAY	-	Transmission coding
SSI:ERRBIT	0		Position of the failure bit

## 8.9 Parameter description of the SSI interface

### 8.9.1 SELECT:X (Define sensor type)

Command	Parameters	Unit	Group
SELECT:X x	x= ANA SSI		STD

The appropriate sensor type can be activated with this command.

**ANA:** The analogue sensor interface (0... 10 V or 4... 20 mA) is active. This sensor is scaled with the AIN:X command.

**SSI:** The SSI sensor interface is active. The SSI sensor is matched to the sensor with the SSI commands. The relevant sensor data must be available.

## 8.9.2 SSI:RANGE (Sensor nominal length)

Command	Parameter	Unit	Group
SSI:RANGE X	x= 10... 10000	mm	SSI

This parameter is used to define the length of the sensor.  
The relevant data are described in the technical data of the sensor.

## 8.9.3 SSI:OFFSET (Sensor offset)

Command	Parameters	Unit	Group
SSI:OFFSET x	x= -200000... 200000	µm	SSI

A sensor offset is entered with this parameter.

## 8.9.4 SSI:POL (Signal direction)

Command	Parameters	Unit	Group
SSI:POL x	x= + -	-	SSI

To reverse the sensor working direction.

## 8.9.5 SSI:RES (Signal resolution)

Command	Parameters	Unit	Group
SSI:RES x	x= 100... 10000	0.01 µm	SSI

The sensor signal resolution<sup>17</sup> is defined with this parameter. Data is entered with the resolution of 10 nm (nanometer or 0,01µm). This means that if the sensor has 1 µm resolution the value 100 must be specified. This also makes it possible to scale rotational sensors. The appropriate data is to be found in the sensor data sheet.

<sup>17</sup> The internal resolution of the module is 1 µm. This is also the lowest resolution of the sensor.

## 8.9.6 SSI:BITS (Number of data bits)

Command	Parameters	Unit	Group
SSI:BITS x	x= 8... 31	bit	SSI

The number of data bits is entered with this parameter.  
The appropriate data is to be found in the sensor data sheet.

## 8.9.7 SSI:CODE (Signal coding)

Command	Parameters	Unit	Group
SSI:CODE x	x= GRAY BIN	-	SSI

The data coding is entered with this parameter.  
The appropriate data is to be found in the sensor data sheet.

## 8.9.8 SSI:ERRBIT (Position of the “out of range” bit)

Command	Parameter	Unit	Group
SSI:ERRBIT x	x= 8... 31	bits	SSI

The position of the error bit will be defined by this parameter.  
The appropriate data is to be found in the sensor data sheet.  
In case of no error bit, the default value is 0.



## 9 Notes